



UM 7825 HYDRAULIC ROUND BALE GRIP

Instruction and spare parts

Edition	2025
Revised	07.01.2025
Language	ENG

Original user manual

Warranty

This Underhaug product is warranted against manufacturing and material defects for a period of one year.

Components not manufactured by Underhaug, such as electrical and hydraulic equipment, power take-off (PTO) shafts, and tires, are covered according to the original manufacturer's warranty terms.

Limited Warranty for Specific Components:

Due to their functional nature, the following components have limited warranty coverage:

Tires, blades, blade tips, shear bolts, fuses, and hydraulic seals in pumps, motors, valves, and cylinders, etc.

Wear and tear resulting from normal use is considered standard for these parts.

Warranty for these components is therefore limited to manufacturing defects such as breakage, deviations in design, or transport damage identified on new machines.

If damage is believed to be covered under the product warranty, the owner or the owner's representative must inform the dealer when requesting parts or repair work. Warranty claims must be reported within the warranty period.

The dealer must complete a claim form for each warranty case and submit it to Underhaug's sales company/importer by the 10th of the month following the report of the damage.

Damaged parts must be labelled with the claim number and retained for up to six months to allow Underhaug's sales company/importer to inspect them.

As the use of Underhaug products occurs outside the manufacturer's control, we can only guarantee the product's quality, not its performance or any resulting damages.

Warranty Exclusions:

The warranty may be voided if:

- a) non-original spare parts are used, or the product is repaired or modified without Underhaug's approval.
- b) The manufacturer's operating and service instructions are not followed.
- c) The machine is used for purposes other than those intended.

The warranty does not cover damage caused by wear and tear.

Public safety regulations require the manufacturer of this machine to carefully assess the safety of its correct use. Therefore, Underhaug and our importer/sales company cannot be held responsible for the function of components not listed in the spare parts catalogue for this product.

Underhaug reserves the right to make design changes without obligation to update previously delivered machines.



Contents

General Safety	pg. 4-8
Supplementary Safety	pg. 9
Machine Applications	pg.10-11
Spare Parts	pg.12
EU Declaration of Conformity	pg. 13

Safety

Before operating the machine

Before operating, adjusting, or repairing the machine, the user, repairer, and owner must familiarize themselves with the safety instructions provided in this manual (Fig 1). Be attentive and cautious when working with agricultural machinery. Read and take note of the safety instructions in this manual.

Safety at work is your responsibility

General safety instructions

Exercise caution when other people or animals are nearby

Never start the machine when people or animals are close to the machine and tractor. Never stand between the tractor wheels and the machine (Fig 2).

Be aware of regulations concerning the operation of agricultural machinery by minors.

Using the machine

The machine should only be used for its intended purpose.

Use personal protective equipment

Do not wear loose clothing that could get caught in moving parts of the machine. Use an approved mask in dusty working conditions (Fig 3).

Be aware of the dangers of high noise levels. Some tractor-implement-combinations may under certain conditions produce noise levels above 85 dB, even inside soundproofed cabs. In such cases, hearing protection must be used. Keep the tractor's

windows and doors closed to reduce the noise level around the driver

Ensure proper tractor compatibility

The tractor's weight must match the machine's maximum working weight. Follow applicable public regulations (Fig 4).

Verify that the correct PTO gear ratio is connected. A machine designed for 540 RPM must never be connected to a tractor with a 1000 RPM. PTO engaged the machine's standard. PTO speed is indicated on a label near the power transmission system.

Important safety symbol



Pay special attention to this symbol. It indicates a safety hazard and outlines precautions to avoid accidents.

This symbol may appear throughout this manual and on warning labels on the machine. They are there for your safety and must be noted.

Connecting the tractor and machine

Always follow the instructions in the manual when connecting the machine. If the connection is made by an agricultural hitch, one part (tractor or machine hitch) must have a clevis design. The hitch pin must be secured with a locking pin (Fig 5).

Follow applicable regulations for road transport

Some countries require the use of safety chains when transporting a towed machine.

Think safety while working

The tractor engine should be stopped and the ignition key removed before performing any repair work, lubrication, or other maintenance on the machine. (Fig. 6).

Protective covers

Ensure that all covers are in good condition and properly mounted. Do not attempt to start the machine until this has been done. Damaged covers should be repaired or replaced immediately. (Fig. 7). Pay special attention to all protective covers related to the power take-off shafts. Replace damaged covers. Safety chains must always be attached to the machine and/or tractor to prevent the protective sleeves from rotating.

Hydraulics

Be cautious when handling hydraulic systems. Wear eye protection and gloves. Oil released under high pressure can penetrate the skin and cause serious internal damage. Seek medical attention if you have been exposed to such injury. (Fig. 8).

Ensure that no one is near the machine when hydraulic functions are operated.



Fig. 1

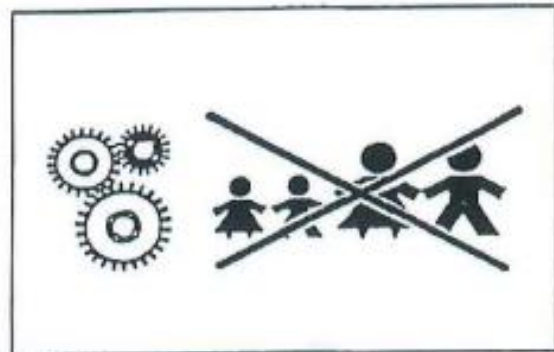

Fig. 2



Fig. 3

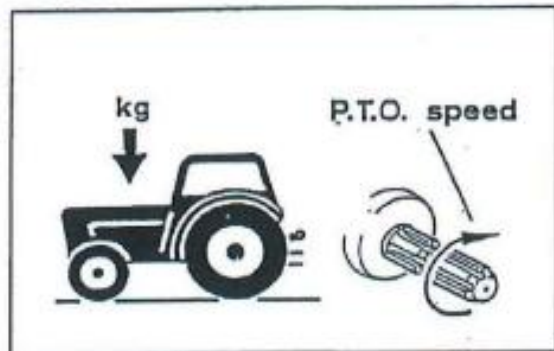

Fig. 4

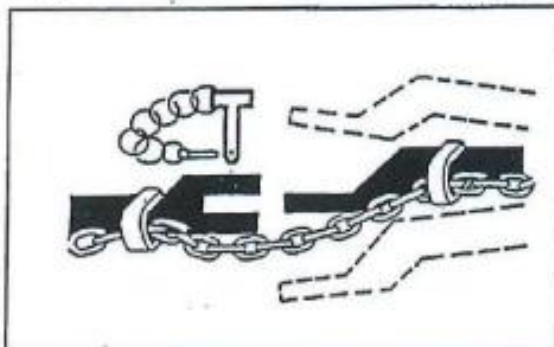

Fig. 5



Fig. 6

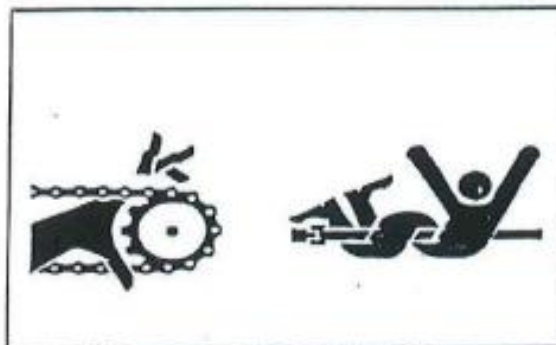

Fig. 7



Fig. 8

When disconnecting the machine and leaving the tractor/machine

Set all hydraulic functions to the neutral position when disconnecting the machine. Lower the movable working components to the ground or set them in the transport position and secure them. If the machine is equipped with parking blocks, these should be used. Do not allow children to play or remain near agricultural machines. (Fig. 9).

Drive Safely

Remember, you are responsible – carelessness and negligence can cause serious injury or even death. (Fig. 10).

Check the wheel bolts and the connection

between the machine and tractor before transport on public roads. Also disconnect the hydraulic system.

Drive carefully. Reduce speed in turns and when driving on uneven surfaces. Ensure that the towed machine does not move uncontrollably sideways.

Be aware of the tipping hazard when driving on slopes and on soil with low bearing capacity. Reduce the load.

Lights

The owner/operator is responsible for equipping the machine with the correct sound and reflectors when driving on public roads. Follow public regulations. (Fig. 11).

Safety equipment

Always carry first aid equipment in the tractor. Follow public regulations regarding fire extinguishing equipment. When working with flammable materials such as hay and straw, fire extinguishing equipment must always be available. (Fig. 12).

Spare parts

For safety reasons, we recommend using only original spare parts. The product warranty is invalid if non-original parts are used. (Fig. 13).

Maintenance

Ensure that the machine is properly maintained and kept in good condition. Never make modifications to the machine's technical design. (Fig. 14).



Fig. 9

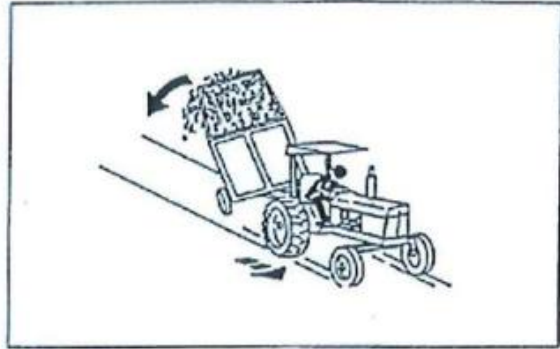

Fig. 10

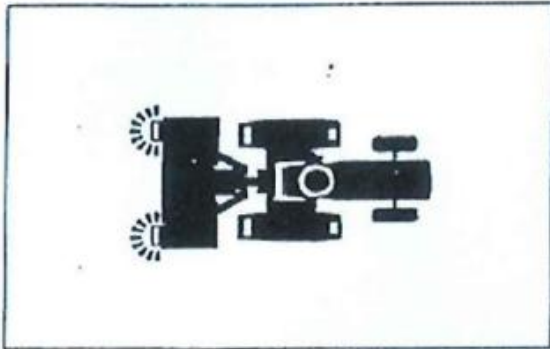

Fig. 11



Fig. 12

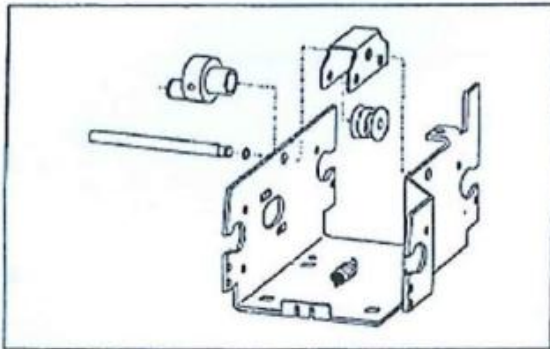



Fig. 13



Fig. 14

Instructions for UM 7825 Hydraulic round bale grip

This equipment is marked with this  warning sign. If the sign is damaged, it must be replaced. Warning sign 220532 (fig. 1). Remember! Read and understand the instruction manual before using the equipment and before adjusting and performing maintenance.

Warning Sign 220532 (Fig. 1). Caution. Read and understand the instruction manual before using the equipment, and before adjusting or performing maintenance.

Warning Sign 220538 (Fig. 2). Due to the high risk of crushing, it is essential to keep people at a safe distance when the equipment is in use.

Warning Sign 220537 (Fig. 3). When the equipment is mounted on the rear of the tractor or on a loader, ensure no one walks underneath the equipment. Also, avoid lifting the equipment too high, as this may cause the load to fall off or the tractor to tip over.



Fig. 1



Fig. 2



Fig. 3

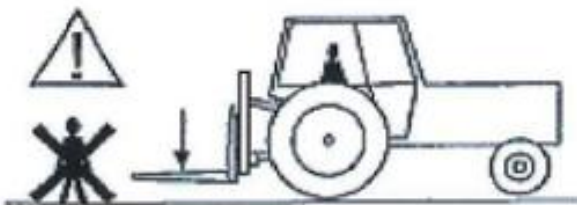

Machine application

Round bale grip with freely pivoting, curved, and rounded gripping arms for gentle handling of round bales. With this model, it is possible to choose whether to stack the bales on their ends, sides, or vertically. The design of the gripping arms ensures that pre-wrapped round bales are transported and stacked without damaging the plastic.

In combination with Underhaug's other single, double, and triple bale handlers, the UM-7825 offers full flexibility to transport between 1 to 4 round bales.

The UM-7825 can handle round bales with diameters ranging from 900 to 1800 mm. The UM-7825 is also equipped with an anti-slip valve, ensuring safer transport over longer distances. We supply the UM-7825 for most front loaders. A double-acting hydraulic outlet on the tractor is required. The lifting capacity is 1200 kg. Supplied with 1-meter hydraulic hoses and ISO couplings.

Underhaug cannot guarantee the strength and/or twisting of the tractor's loading equipment and front axle.

Technical Data	
Weight:	180 kg + load attachment
Dept:	1280 mm
Width:	2030 mm (open) 1350 mm (locked)
Height:	810 mm
Lifting capacity:	900-1800 mm

Connection to tractor

The round bale grip is attached to the front loader and secured.

The load securing points are welded in place at the factory in advance, according to the customer's specifications.

The hydraulic hoses are connected to a double-acting control valve, which operates the grabber.

The front loader must have a hydraulically adjustable implement hitch.

Use of the round bale grip

Adjust the gripping arms to be parallel to the ground.

Move the arms to the outer position before driving the grabber towards the bale.

Press the arms against the bale so that it is securely gripped.

Lift the bale.

Heavy bales are most safely transported hanging (lying down). If the bale is to be stacked standing on its end, it should be turned upright just before stacking for safety reasons.

When stacking the bales, ensure that the gripping arms does not encounter other bales and damage their plastic.

Maintenance

Avoid exposing the cylinder to aggressive environments. Apply grease to the piston rod or fully extend the gripping arms during long-term storage.

Grease all lubrication points daily.

Keep the bale grabber clean. Avoid dirt on the hydraulic connections.

Protect shiny parts from rust.

Grind down any sharp edges on the gripping arms and frame.

Ordering no

UM-7825 with 3-point bracket

UM-7826 with Trima / Ålø / HVM bracket

UM-7827 with Lyng triangle bracket

UM-7828 with Euro bracket

SPARE PARTS FIG. 1 UM 7825

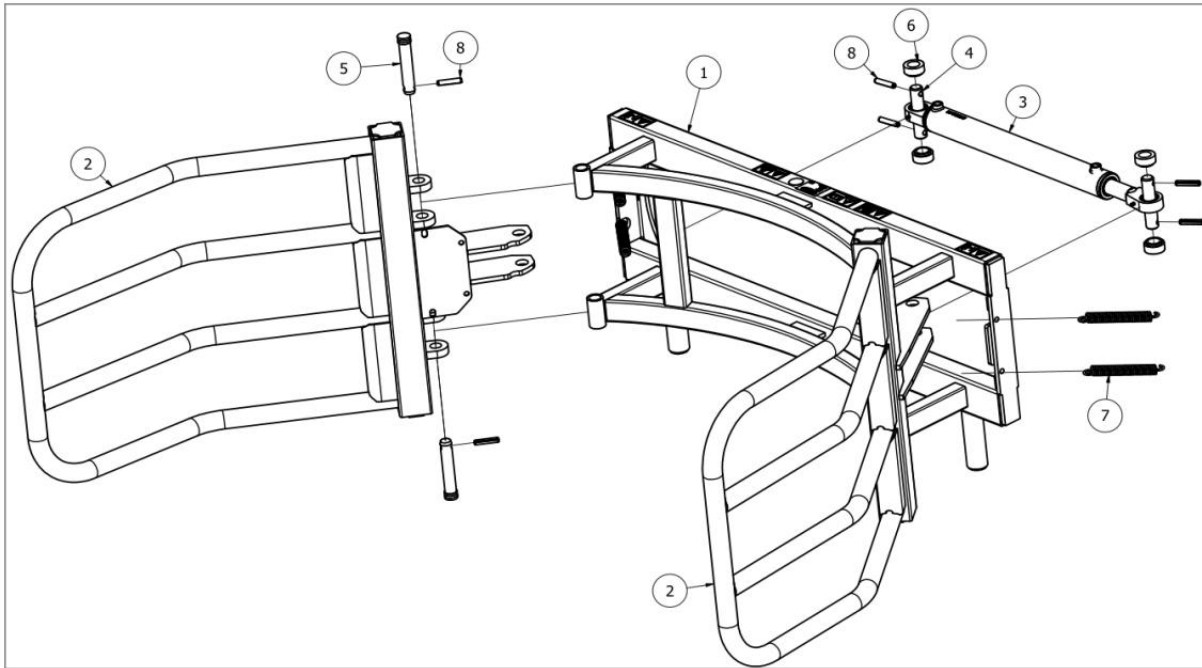

Ref no.	Part no.	Qty.	Item	Discription	Note
1	409080	1	Frame welded		
2	409090	2	Arm welded		
3	419095	1	Sylinder for UM 7825		
4	419094	2	Mounting bolt for sylinder		
5	419093	4	Mounting bolt for arm		
6	419097	4	Spacer sleeve		
7	419096	4	Tension spring Ø25x4x191		
8	866660	8	Clamping sleeve 12x60		

Not illustrated

	419101	1	Hydraulic set UM 7825		
--	--------	---	-----------------------	--	--



EU - DECLARATION OF CONFORMITY

Responsible person

Name	Atle Årslund
Position	General Manager
Company	Underhaug AS
Address	Torlandsvegen 3 4365 Nærbø, NORWAY
Phone	+47 51 43 49 78

Declares that the following machine:

Manufacturer:	Underhaug AS
Type:	<i>UM 7825 Round bale Grip</i>
Serial Number:	
Production Year:	

complies with the following directive:

Maximum regulation 554 (for 2009-05-20-554) and meets essential health and safety requirements.

Basic standard ISO 12100

A handwritten signature in blue ink, appearing to read "Atle Årslund".

Atle Årslund

Nærbø, date



Torlandsvegen 3 – P.Box 183

N-4367 Nærbø, Norway

Phone: +47 51 43 49 78

Email: post@underhaug.no

www.underhaug.no/eng