



## UM 7926/7934/7942/7950/7966 Direct Seeding Machine

### Instruction and spare parts

Edition	2025
Revised	01.01.2025
Language	ENG

Original user manual

## **Warranty**

This Underhaug product is guaranteed against manufacturing and material defects for one year. Components not produced by Underhaug, such as electrical and hydraulic equipment, power take-off shafts, and tires, are covered according to the original manufacturer's warranty terms.

The following components have limited warranty terms due to their function: tires, skirts, blade tips, breaker pins, fuses, hydraulic seals in pumps, motors, valves, cylinders, etc., as found on new machines. Deterioration due to wear and tear during use is considered normal for these parts. Therefore, the warranty for these parts is limited to manufacturing defects such as breakage, deviations in workmanship, transport damage, etc., found on a new machine.

If damage is expected to be covered by the product warranty, the owner or the owner's representative must inform the dealer when parts and/or repair work are requested. Warranty claims must be reported within the warranty period. The dealer must complete a claim form for each warranty case and send it to Underhaug's sales company/importer by the 10th of the month following the damage report.

The damaged parts must be marked with the claim form number and stored for up to 6 months so that Underhaug's sales company/importer can inspect the parts.

Since the use of Underhaug products occurs outside of the manufacturer's control, we can only guarantee product quality, not performance or any consequential damages.

The warranty may be voided if: a) non-original spare parts are used or the product is repaired or modified without Underhaug's approval. b) The manufacturer's usage and service instructions have not been followed. c) The machine is used for purposes other than what it was designed for.

The warranty does not cover damage due to wear and tear.

Public safety regulations require the manufacturer of this machine to carefully assess safety during proper use of this machine type. Therefore, Underhaug and our importer/sales company are not responsible for the function of components not shown in the spare parts catalogue for this product.

Underhaug reserves the right to make design changes without obligation for previously delivered machines.



# Contents

<b>General Safety .....</b>	<b>pg. 4-8</b>
<b>Supplementary Safety .....</b>	<b>pg. 9</b>
<b>Technical Data.....</b>	<b>pg.10</b>
<b>The intended use of the machine.....</b>	<b>pg. 11-20</b>
<b>Spare Parts .....</b>	<b>pg.21-30</b>
<b>EU Declaration of Conformity .....</b>	<b>pg. 31</b>

## Safety

### Before operating the machine

Before operating, adjusting, or repairing the machine, the user, repairer, and owner must familiarize themselves with the safety instructions provided in this manual (Fig 1). Be attentive and cautious when working with agricultural machinery. Read and take note of the safety instructions in this manual.

Safety at work is your responsibility

### General safety instructions

Exercise caution when other people or animals are nearby

Never start the machine when people or animals are close to the machine and tractor. Never stand between the tractor wheels and the machine (Fig 2).

Be aware of regulations concerning the operation of agricultural machinery by minors.

### Using the machine

The machine should only be used for its intended purpose.

### Use personal protective equipment

Do not wear loose clothing that could get caught in moving parts of the machine. Use an approved mask in dusty working conditions (Fig 3).

Be aware of the dangers of high noise levels. Some tractor-implement-combinations may under certain conditions produce noise levels above 85 dB, even inside soundproofed cabs. In such cases, hearing protection must be used. Keep the tractor's

windows and doors closed to reduce the noise level around the driver

### Ensure proper tractor compatibility

The tractor's weight must match the machine's maximum working weight. Follow applicable public regulations (Fig 4).

Verify that the correct PTO gear ratio is connected. A machine designed for 540 RPM must never be connected to a tractor with a 1000 RPM. PTO engaged the machine's standard. PTO speed is indicated on a label near the power transmission system.

### Important safety symbol



Pay special attention to this symbol. It indicates a safety hazard and outlines precautions to avoid accidents.

This symbol may appear throughout this manual and on warning labels on the machine. They are there for your safety and must be noted.

### Connecting the tractor and machine

Always follow the instructions in the manual when connecting the machine. If the connection is made by an agricultural hitch, one part (tractor or machine hitch) must have a clevis design. The hitch pin must be secured with a locking pin (Fig 5).

Follow applicable regulations for road transport

Some countries require the use of safety chains when transporting a towed machine.

**Think safety while working**

The tractor engine should be stopped and the ignition key removed before performing any repair work, lubrication, or other maintenance on the machine. (Fig. 6).

**Protective covers**

Ensure that all covers are in good condition and properly mounted. Do not attempt to start the machine until this has been done. Damaged covers should be repaired or replaced immediately. (Fig. 7). Pay special attention to all protective covers related to the power take-off shafts. Replace damaged covers. Safety chains must always be attached to the machine and/or tractor to prevent the protective sleeves from rotating.

**Hydraulics**

Be cautious when handling hydraulic systems. Wear eye protection and gloves. Oil released under high pressure can penetrate the skin and cause serious internal damage. Seek medical attention if you have been exposed to such injury. (Fig. 8).

**Ensure that no one is near the machine when hydraulic functions are operated.**

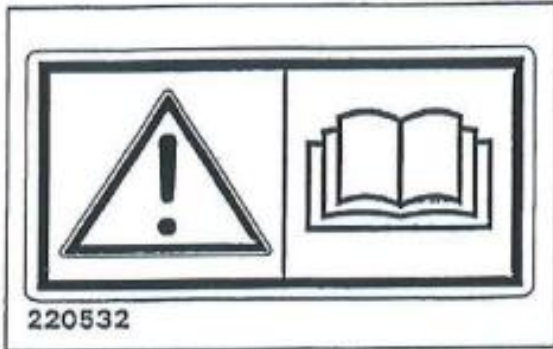

Fig. 1

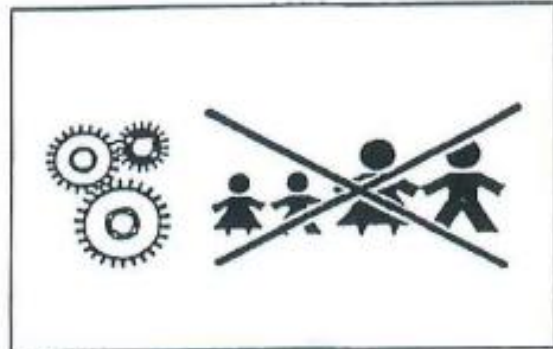

Fig. 2



Fig. 3

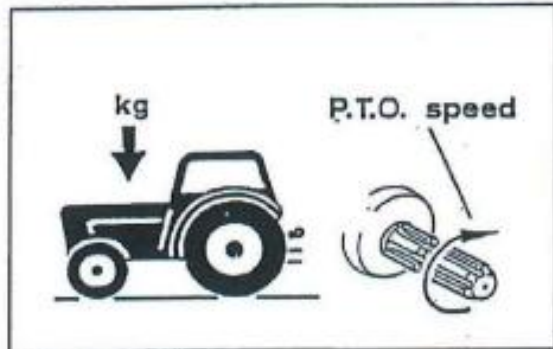

Fig. 4

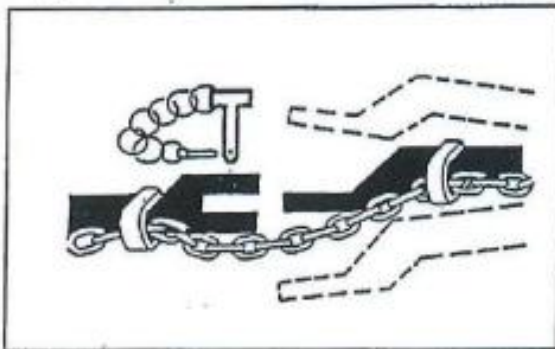

Fig. 5

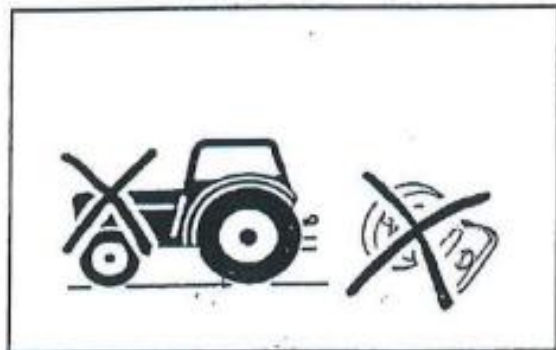

Fig. 6

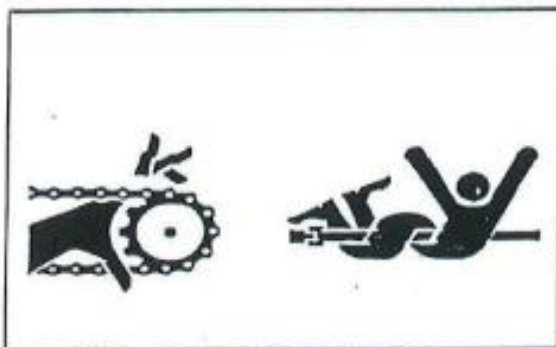

Fig. 7



Fig. 8

### **When disconnecting the machine and leaving the tractor/machine**

Set all hydraulic functions to the neutral position when disconnecting the machine. Lower the movable working components to the ground or set them in the transport position and secure them. If the machine is equipped with parking blocks, these should be used. Do not allow children to play or remain near agricultural machines. (Fig. 9).

### **Drive Safely**

Remember, you are responsible – carelessness and negligence can cause serious injury or even death. (Fig. 10).

### **Check the wheel bolts and the connection**

between the machine and tractor before transport on public roads. Also disconnect the hydraulic system.

Drive carefully. Reduce speed in turns and when driving on uneven surfaces. Ensure that the towed machine does not move uncontrollably sideways.

Be aware of the tipping hazard when driving on slopes and on soil with low bearing capacity. Reduce the load.

### **Lights**

The owner/operator is responsible for equipping the machine with the correct sound and reflectors when driving on public roads. Follow public regulations. (Fig. 11).

### **Safety equipment**

Always carry first aid equipment in the tractor. Follow public regulations regarding fire extinguishing equipment. When working with flammable materials such as hay and straw, fire extinguishing equipment must always be available. (Fig. 12).

### **Spare parts**

For safety reasons, we recommend using only original spare parts. The product warranty is invalid if non-original parts are used. (Fig. 13).

### **Maintenance**

Ensure that the machine is properly maintained and kept in good condition. Never make modifications to the machine's technical design. (Fig. 14).



Fig. 9

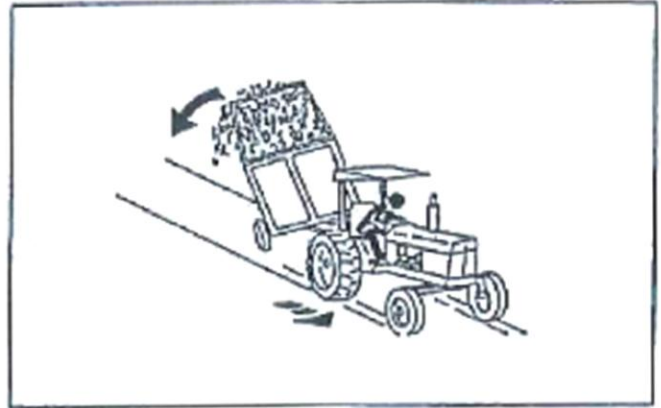

Fig. 10

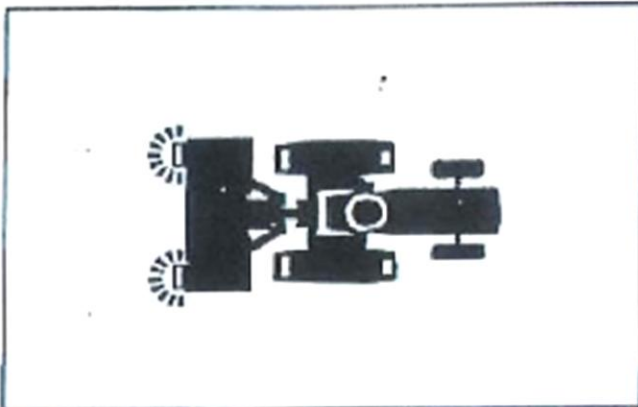

Fig. 11

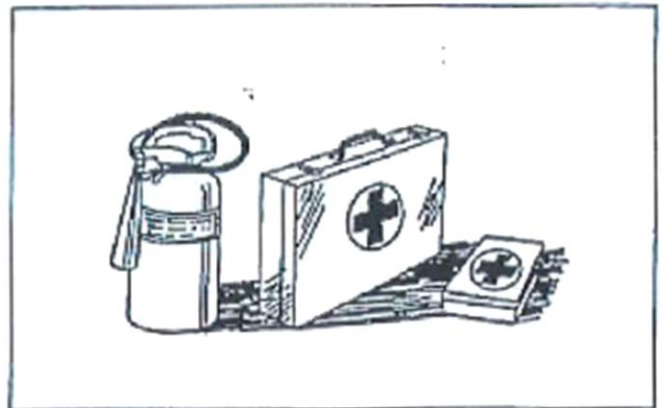

Fig. 12

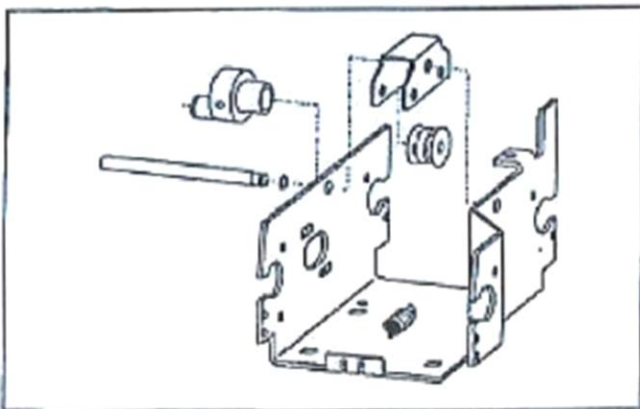



Fig. 13



Fig. 14

## Supplementary Safety Instructions for UM 7926/7934/7942/7950/7966

### Direct Seeding machines

This machine is marked with this  warning sign. If the sign is damaged, it must be replaced. Warning sign 220532 (fig. 1). Remember! Read and understand the instruction manual before using the equipment and before adjusting and performing maintenance.

**Warning Sign 220532 (Fig. 1).** Caution. Read and understand the instruction manual before using the equipment, and before adjusting or performing maintenance.

**Warning Sign 220538 (Fig. 2).** Due to the high risk of crushing, it is essential to keep people at a safe distance when the equipment is in use.

**Warning Sign 220537 (Fig. 3).** When the equipment is mounted on the rear of the tractor or on a loader, ensure no one walks underneath the equipment. Also, avoid lifting the equipment too high, as this may cause the load to fall off or the tractor to tip over.



Fig. 1

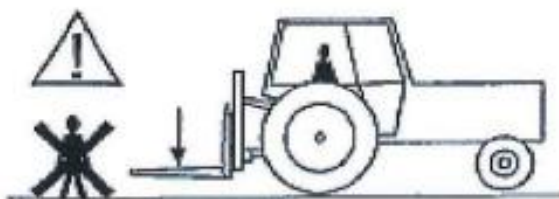

Fig. 2



Fig. 3

Betjeningsplass for operatør:



## Technical data

	<b>UM 7926</b>	<b>UM 7932</b>	<b>UM 7942</b>	<b>UM 7950</b>	<b>UM 7966</b>
Work. width	1,5 m	2,0 m	2,5 m	3,0 m	4,0 m
Seed box	160 L	215 L	270 L	320 L	560 L
Row space.	6 cm	6 cm	6 cm	6 cm	6 cm
No. of rows	26	34	42	50	66
No. of skis	13	17	21	25	33
Ski pressure	10-75 kg	10-75 kg	10-75 kg	10-75 kg	10-75 kg

	<b>UM 7926</b>	<b>UM 7932</b>	<b>UM 7942</b>	<b>UM 7950</b>	<b>UM 7966</b>
Max. width	1,95 m	2,45 m	2,95 m	3,45 m	4,45 m
Max. hight	1,22 m	1,22 m	1,22 m	1,22 m	1,3 m
Drag width	-	-	-	2,1 m	2,1 m
Drag length	-	-	-	5,1 m	6,1 m
Machine weight	400 kg	530 kg	670 kg	800 kg	1050 kg
Tot. weight w/drag	-	-	-	1050 kg	1300 kg

## Preparation of a new machine

The seeder is delivered fully assembled from the factory, except for the drive wheels and drive chains for the seed boxes.

These must be installed afterward. The machine is delivered securely strapped to a transport pallet. Once the packing straps are released, the machine can be lifted off the pallet and connected to the tractor's three-point hitch.

## Assembly of drive wheels and chains

First, mount the drive wheel (6) with the arm and chain drive onto the mounting bracket on the frame using the bolt (12) for the sprocket, as shown in the figure. Then, attach the drive chain between the sprocket on the drive arm and the sprocket on the rear seeding roller axle. The chain that drives the front seeding roller axle and the stirring shafts is pre-installed from the factory.

Tighten the chains, and then install the covers.

The drive wheel arm rests against a pin (20), which should be placed in the rear hole of the mounting bracket when the machine is lifted or when the engine is running.

During transport, the drive wheel should be lifted and secured with the pin in the front hole of the mounting bracket.

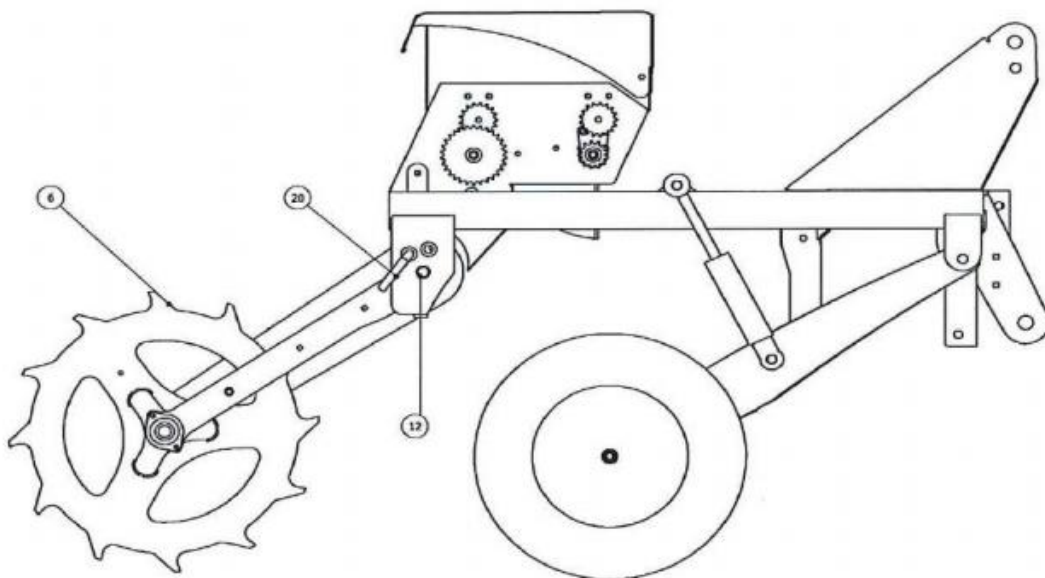

## Transport

Due to the large transport width, a detachable transport drawbar has been developed for towing on roads.

This is an optional feature for the 3.0 m seeder and standard for machines larger than this. The towing drawbar kit has *article number 196100*.

## Seed Box

The seeder is equipped with a seed box specifically designed for sowing grass seeds. Inside the seed box, a dedicated stirring shaft ensures even seed distribution and prevents bridging within the box.

The seeding system operates on a sliding roller principle. The output rollers feature longitudinal rollers that can be adjusted in and out of the seed housings to control the seeding rate. The longitudinal shaft that the seed rollers are mounted on can be adjusted by a screw handle located inside the protective cover on the left side of the seed box. The screw handle locks into the desired position.

The seed rollers and stirring shaft are driven by a separate drive wheel (ground wheel). The drive is transmitted via sprockets and chains. Most moving parts in the seed box are made from a plastic material, ensuring minimal maintenance and long service life.

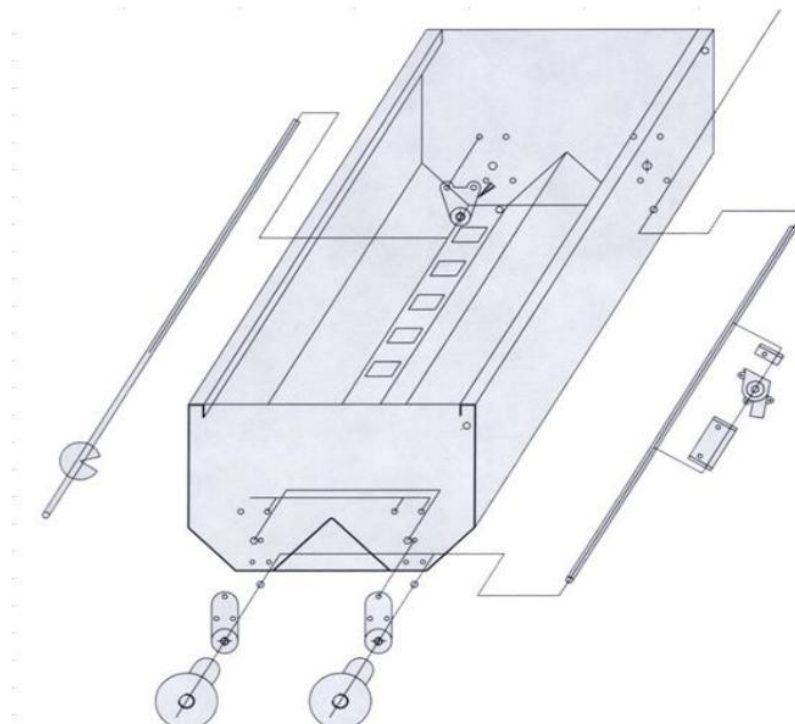

### Adjustment of Seed Output

The seed rates indicated in the table on the machine are approximate. The properties of a seed variety can vary from year to year and depend on the humidity. Therefore, it is recommended to perform a calibration test before starting the seeding operation to ensure that the set seed rate is accurate.

<b>Scale Setting</b>			
<b>Seed type</b>	<b>6</b>	<b>9</b>	<b>15</b>
	<b>KG/Da</b>	<b>KG/Da</b>	<b>KG/Da</b>
Ryegrass Meroa 2-Year			
Sprout silage Plus 10			
Sprout silage normal			
Sprout silage pasture normal	0,66	10	15
FK lawn seed sports	0,66	6,6	10
English Ryegrass Napoleon perennial	0,33	5	8,25
Sprout pasture Plus 80			
Sprout silage Plus 90	0,33	5	8,3
Sprout silage Plus 100	0,66	10	15

***This is only a guideline table, and we always recommend performing a calibration test!***

## Calibration Test

1. Find the seed variety (or equivalent) to be sown in the sowing table.
2. Refer to the table to determine how many kg/ha should be sown and the corresponding setting on the adjustment handle. The adjustment handle is located at the end of the seed box and has a scale from 0-21. Each rotation corresponds to a 3 mm adjustment of the seeding rollers. Turning clockwise reduces the seed rate, while turning counterclockwise increases it.
3. Check that the sprockets have the correct gearing and lift the machine using the tractor's hydraulics.
4. Place a low, long box, plastic sheet, or similar under the seed outlets and seeding rollers to easily collect and weigh the seed being dispensed. Rotate until seed comes out of all the outlets. During the calibration test, always rotate the drive wheel when it is in the transport position, allowing it to rotate freely. Return the seeds to the box, and the actual calibration test can now begin.

It's also possible to collect a sample from one or more hoses in a bag to estimate the seed amount and multiply by the total number of hoses for the total seed amount.

5. Rotate the handle on the seed axle or directly on the drive wheel the number of times indicated in the rotation table on page 12. Collect and weigh the seed dispensed. Adjust the setting handle clockwise for less seed, counterclockwise for more. For machines with an area meter, it is not necessary to count the rotations. Reset the area meter before starting the calibration test and check the area meter once the desired area is reached.
6. Repeat the calibration test until the desired seed rate is achieved.
7. **Important!** When the seed housings are set to full discharge (rollers fully in), ensure the roller does not press against the seed housing wall. Therefore, turn the handle half a turn back.

Standard =  $21/30 \times 21/30 = 0.5$   
 Option 1 =  $30/30 \times 21/30 = 0.7$   
 Option 2 =  $21/30 \times 13/30 = 0.3$

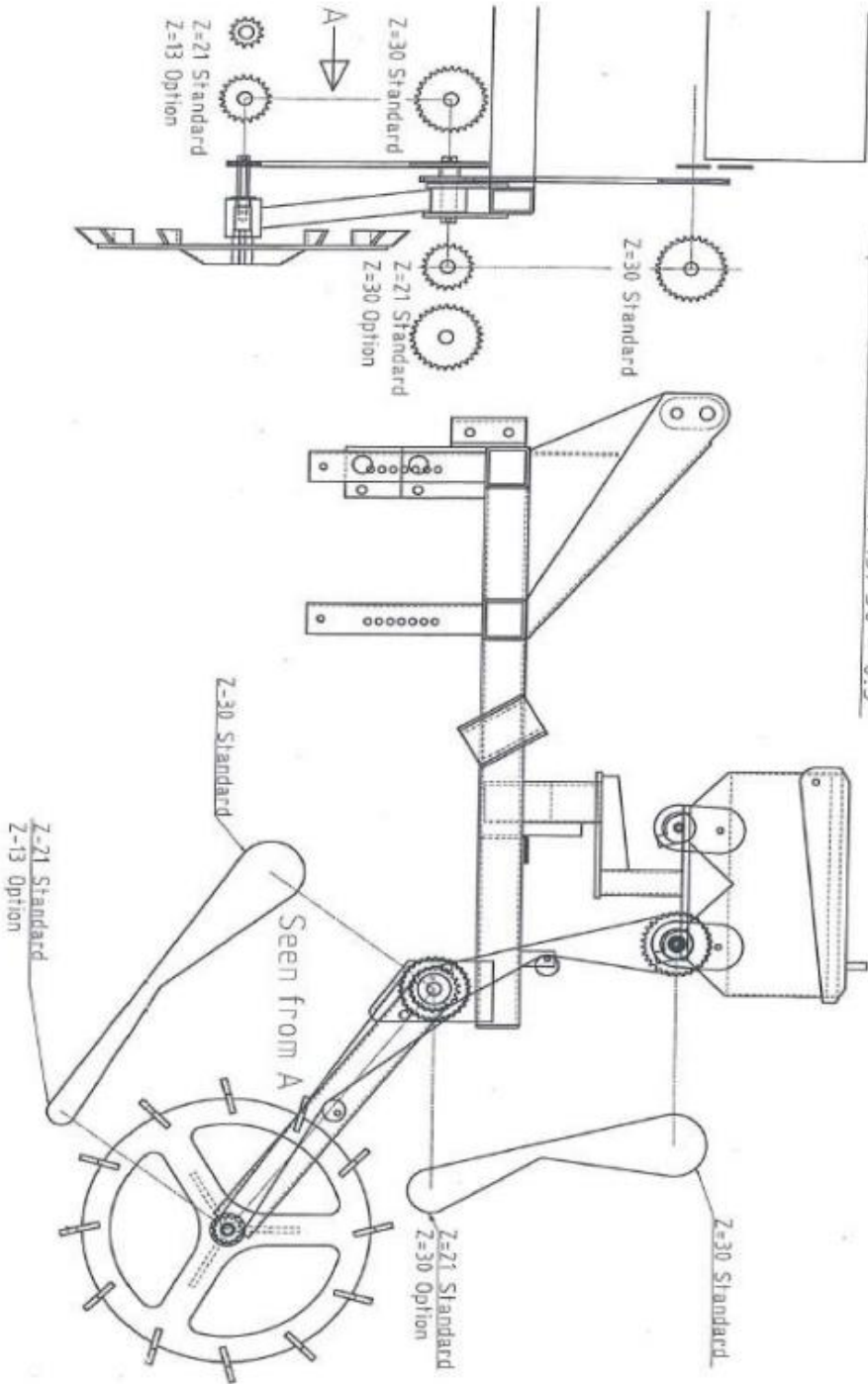

## ROTATION TABLE IN DEKARES

Rotation measured on the **drive wheel**

	¼ da	½ da	1 da
UM-7926 1,5 m	93	185	370
UM-7934 2,0 m	69	138	277
UM-7942 2,5 m	56	111	222
UM-7950 3,0 m	46	92	185
UM-7966 4,0 m	34	69	137

Rotation measured on the **seed box**

	¼ da	½ da	1 da
UM-7926 1,5 m	46	93	185
UM-7934 2,0 m	35	69	139
UM-7942 2,5 m	28	56	111
UM-7950 3,0 m	23	46	93
UM-7966 4,0 m	17	34	69

### Example 1: Kilograms per hectare

Calibration test on a 2.5-meter seeder.

Rotate the drive wheel 56 times, which corresponds to ¼ dekar (250 m<sup>2</sup>). The seed dispensed is weighed, and the measured seed amount is multiplied by 4. This gives the seed rate in kg/ha.

Note: 1 dekar = 1 mål = 1,000 m<sup>2</sup>.

## ROTATION TABLE IN HECTARES

Rotation measured on the **drive wheel**

	1/40 ha	1/20 ha	1/10 da
UM-7926 1,5 m	93	185	370
UM-7934 2,0 m	69	138	277
UM-7942 2,5 m	56	111	222
UM-7950 3,0 m	46	92	185
UM-7966 4,0 m	34	69	137

Rotation measured on the **seed box**

	1/40 ha	1/20 ha	1/10 ha
UM-7926 1,5 m	46	93	185
UM-7934 2,0 m	35	69	139
UM-7942 2,5 m	28	56	111
UM-7950 3,0 m	23	46	93
UM-7966 4,0 m	17	34	69

### Example 2: Kilograms per hectare

Calibration test on a 3.0-meter seeder.

Rotate the drive wheel 46 times, which corresponds to 1/40 hectare (250 m<sup>2</sup>). The seed dispensed is weighed, and the measured seed amount is multiplied by 40. This gives the seed rate in kg/ha.

Note: 1 hectare = 10 decares = 10,000 m<sup>2</sup>.

### **Frame with Seed Skis**

The seed skis (seed plates) with arm and pressure spring are mounted in a parallelogram configuration on the frame. The seed ski itself is attached to the arm in such a way that it is movable, allowing it to absorb small unevenness in the ground. The suspension arm is pushed downward by a pressure spring, and the spring arm also has a stopper that keeps the seed ski lifted off the ground when the machine is raised by the three-point hitch.

### **Adjustment of Pressure on Seed Skis**

The pressure on the seed skis is adjusted by raising or lowering the hydraulic cylinders on the depth wheels. The pressure is continuously adjustable from approximately 15 kg up to about 75 kg. If more than 30 kg of ski pressure is needed, extra ballast must be added to the machine. (Additional ballast weights are available for this: part no. 7968 for 2.5m, 7969 for 3.0m, and 7970 for 4.0m).

If operating on “normal” pasture and with the standard weight of the machine, the machine works best when the depth wheels are lifted off the ground. These are only necessary to use if the soil is soft/wet or if minimal force must be applied to the surface (e.g., golf courses).

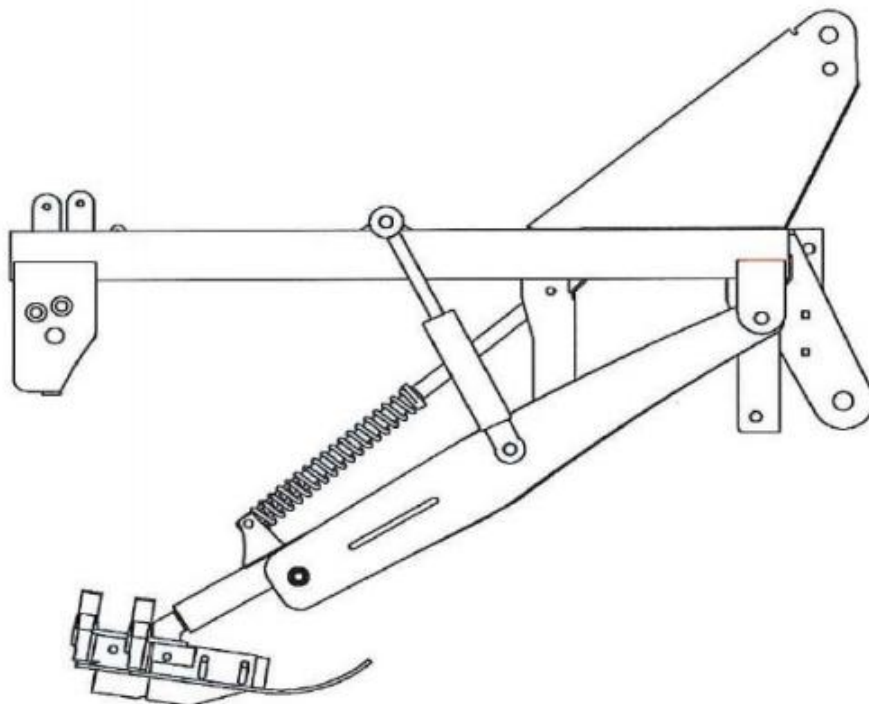

## Adjustment of Knife Depth

Each seed ski is equipped with two hardened steel knives that create two seed furrows in the grass when the seed ski slides with pressure against the ground. The knives have two elongated holes at the front and are fastened through these to the seed ski with two bolts. At the rear, there is a stop bolt that prevents the knife from lifting, either due to repeated impacts against hard stones or when driving in extra hard soil.

When adjusting the knives up or down, it is important to tighten the two front bolts on each knife securely and to re-adjust the stop bolt so that it makes contact with the knife. In typical pasture, a knife depth of 1.5–2 cm is commonly used, while seeding in fields with sprayed grass requires a slightly deeper knife setting. On new machines delivered from the factory, the knives are set to 2 cm.

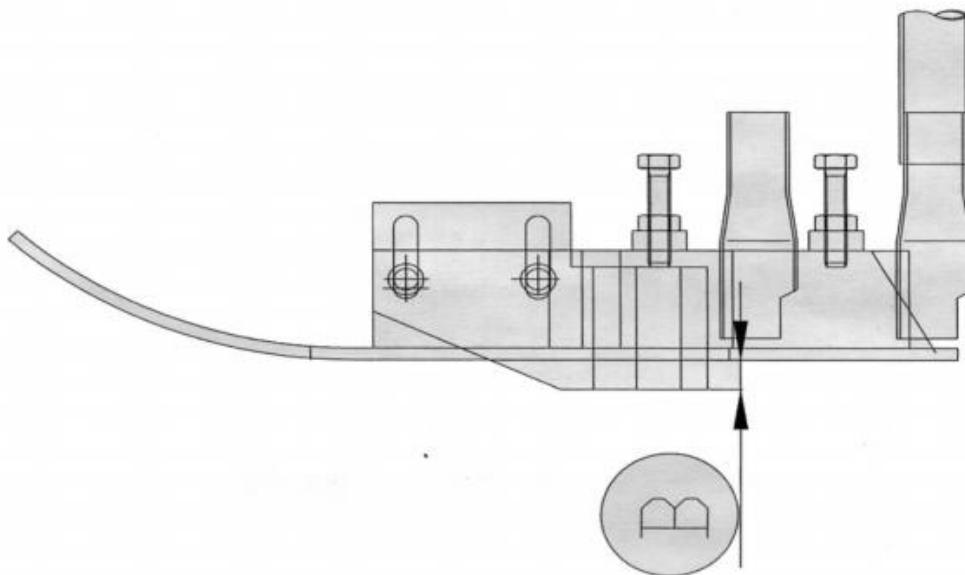

## **Practical Tips**

### **Seeding Speed**

Since seed dispensing occurs with ribbed seed rollers, there is a practical upper limit to the speed at which you can operate the seeder. If the seed rollers spin too quickly, the seed does not have enough time to fall into the furrows, and the seed rate decreases as roller speed increases. This needs to be tested experimentally. However, driving speeds of 5-8 km/h usually work without issues.

### **Knives**

The standard machine is equipped with 3mm knives. However, there may be cases where the knives struggle to cut properly, especially in well-established grass areas such as parks, football/golf fields, and some marshy terrain. In such cases, it is recommended to switch to 2mm knives, which cut more easily through the grass sod. It can also help to sharpen the knives. To do this, the knives need to be removed and sharpened individually using a grinding wheel. It's important not to grind too much, as this may cause the steel to discolor (purple/red), which weakens the hardening of the knife.

### **Pressure on Seed Skis**

The pressure is adjusted continuously using hydraulic cylinders on the depth wheels, and the pressure on the seed skis is pre-tensioned to approximately 10 kg. The maximum pressure with the standard machine is around 30 kg, which is sufficient in most cases. However, when the soil is hard, additional ballast must be added to the machine to achieve more pressure on the seed skis. This can be supplied as an optional extra. In cases where the soil is particularly soft or moist, especially in newly cultivated grassland or black earth, the pressure should be reduced to a minimum by raising the depth wheels as described above.

### **Spraying with Roundup**

In some cases, it is desirable to spray the land with Roundup. Based on experiences, it is generally fine to seed after spraying. However, there are certain risks associated with seeding after Roundup spraying, especially if you seed 6-10 days after spraying. During this period, a suffocating gas is formed that prevents new seeds from germinating. Seeding during this time results in almost no germination. Experiences also show that the best effect is achieved by spraying the land in the fall and seeding in the spring. It is recommended to contact the herbicide supplier to investigate the risks of spraying and direct seeding.

### **Direct Seeding**

The primary purpose of the direct seeder is the repair and renewal of poor-quality grassland. When seeding in established grass, it is always with the goal of improving germination for the next year. The recommendation is to seed twice a year, with slightly lower seed rates than usual: early spring and late summer, preferably right after the second mowing. It is important to continue this practice every year, as experience shows that this yields the best results and eliminates the need for soil cultivation for several years.

## **Troubleshooting**

### **Adjustment Handle is Stiff**

There may be sand or dirt in the threads of the adjustment handle or in the seed rollers. Clean if necessary and lubricate with silicone spray.

### **Seed Rate Changes During Seeding**

Check if there is any play or wear between the seed axle and the adjustment handle, and if necessary, adjust by adding an extra tension washer between them.

### **Uneven Seed Dispensing from One Seed Box**

This should normally not happen, as the seed rollers are adjusted at the factory. However, a seed roller may become displaced due to impacts or shocks. If a seed roller has shifted slightly, it should be adjusted back to align with the others. Foreign objects in a seed box can also cause inconsistent seed dispensing.

FIGUR 1

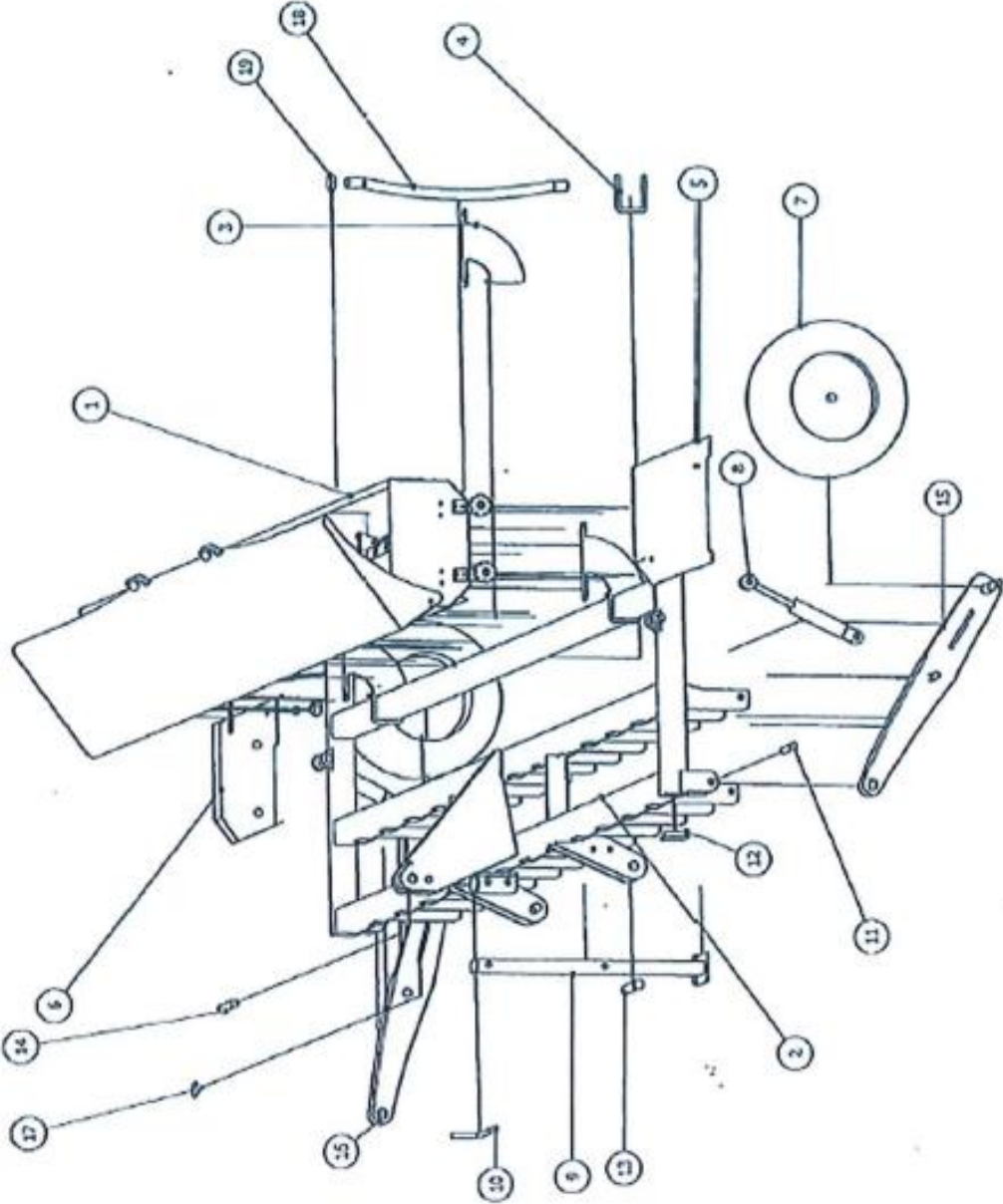

**SPARE PARTS FIG. 1**

<b>Ref.</b>	<b>Part No.</b>	<b>Qty</b>	<b>Item Description</b>
1	190415	1	Seed Box COMPLETE 1.5 m
	190420	1	Seed Box COMPLETE 2.0 m
	190425	1	Seed Box COMPLETE 2.5 m
	190430	1	Seed Box COMPLETE 3.0 m
2	190023	1	Frame COMPLETE 1.5 m
	190024	1	Frame COMPLETE 2.0 m
	190025	1	Frame COMPLETE 2.5 m
	190185	1	Frame COMPLETE 3.0 m
3	190889	3 (2)	Box Holder
4	190172	3 (2)	Shackle 80x80 mm
5	190894	1	Cover V
6	190893	1	Cover H
7	190017	2	Wheel COMPLETE
8	190878	2	Cylinder COMPLETE
9	190050	1	Support Foot
10	190060	1	Adjusting Bolt
11	190876	2	Bolt for Wheel Suspension
12	190065	4	Plastic Plug 80x50x5 Pipe
13	190908	2	Drawbar Bolt
14	190058	1	Top Link Bolt
15	190870V	1	Wheel Arm Left
16	190870	1	Wheel Arm Right
17	921702	5	Tie Pin
18	190180	26-50	Downpipe Hose
19	190181	52-100	Hose Clamp

FIGUR 2

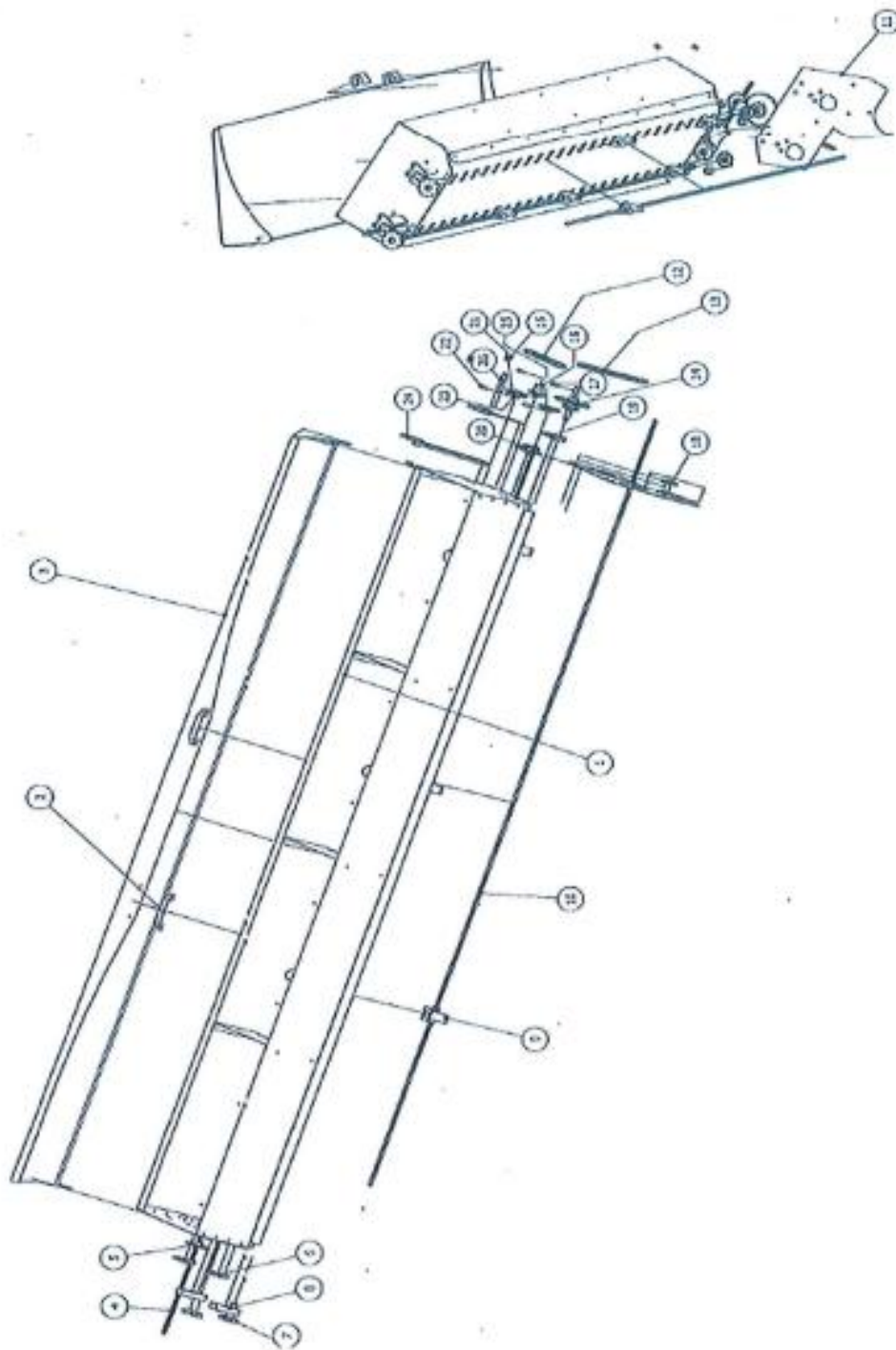

## SPARE PARTS FIG. 2

Ref.	Part No.	Qty	Item Description
1	190416	1	Seed Box 1.5 m
	190421	1	Seed Box 2.0 m
	190426	1	Seed Box 2.5 m
	190431	1	Seed Box 3.0 m
2	190903	2	Handle for Cover
3	190418	1	Cover 1.5 m
	190423	1	Cover 2.0 m
	190428	1	Cover 2.5 m
	190433	1	Cover 3.0 m
4	190451	2	Shaft 1.5 m
	190453	2	Shaft 2.0 m
	190455	2	Shaft 2.5 m
	190457	2	Shaft 3.0 m
5	190445	26-50	Spacer Plate
6	190443	4-8	Support Bearing
7	190407	2	Adjustment Handle
8	190440	2	Mounting for Adjustment Handle
9	190440	26-50	Seed Housing COMPLETE
10	190452	2	Seed Shaft 1.5 m
	190454	2	Seed Shaft 2.0 m
	190456	2	Seed Shaft 2.5 m
	190458	2	Seed Shaft 3.0 m
11	190896	1	Inner Cover F, Chain Drive
12	190477	1	Chain for Seed Box
13	190478	1	Chain Seed Box to Drive Wheel
14	190437	1	Double Gear
15	190907	2	Chain Lock 3/4" COMPLETE
16	190411	1	Sprocket 13z Black
17	190414	2	Spacer for Sprocket
18	190900	1	Chain Tensioner COMPLETE
19	190434	2	Support Bearing with Hole
20	190882	1	Short Chain Tensioner COMPLETE
21	190279	1	Sprocket 17z for Shaft
22	190286	2	Spacer Washer Seed Box
23	190278	4	Stop Ring for Shaft
24	190280	2	Support Bearing COMPLETE
25	190285	1	Sprocket 17z Black
26	190178	2	Shaft Extender, Stainless Steel

FIGUR 3

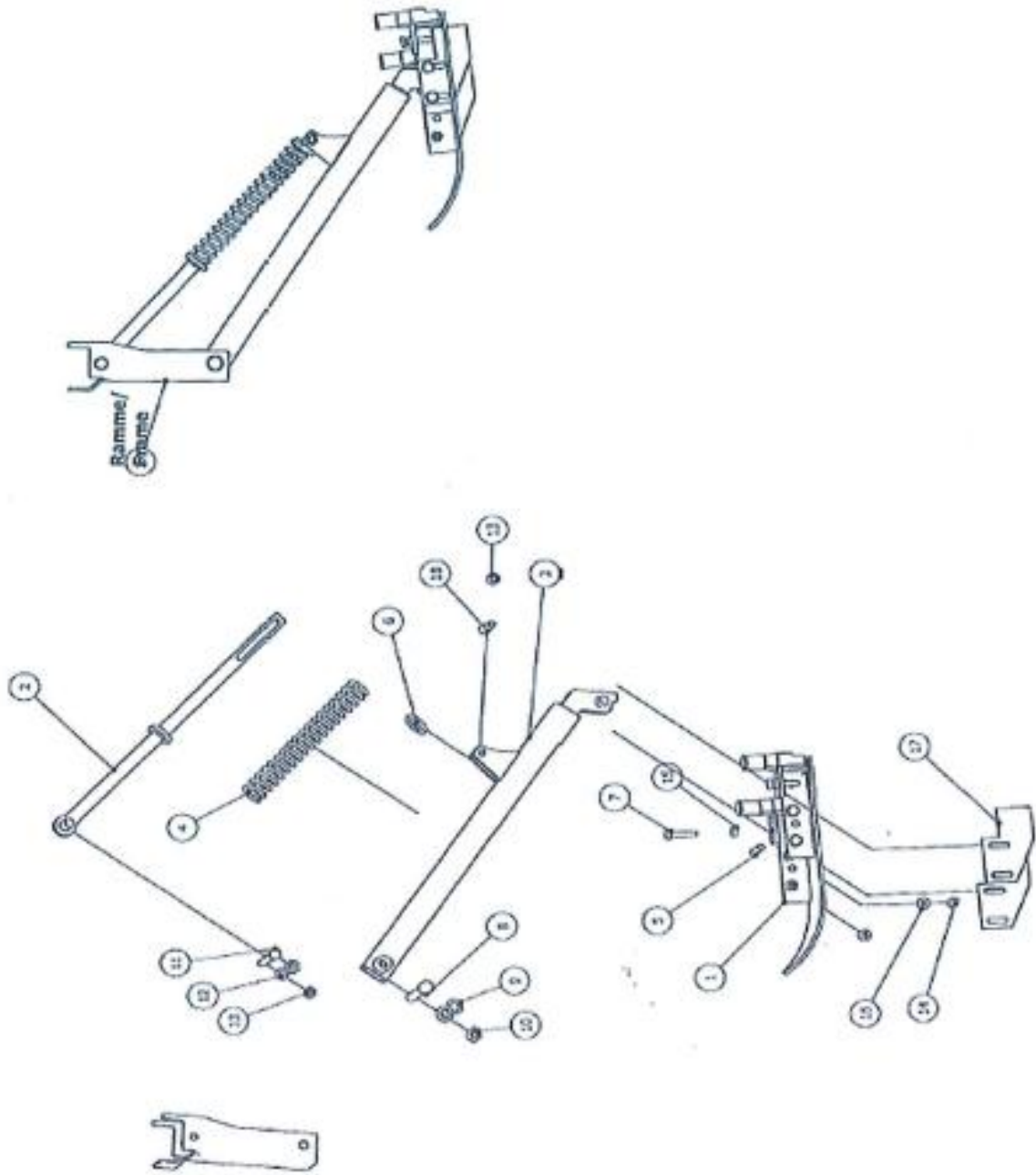

### SPARE PARTS FIG. 3

Ref.	Part No.	Qty	Item Description
1	190835	13-25	Shoe Assembly COMPLETE
2	190865	13-25	Spring Arm Black
3	190888	13-25	Ski Arm Black
4	190883	13-25	Compression Spring
5	190839	13-25	Cotter Pin
6	190852	13-25	Washer for Compression Spring
7	813550	26-50	Hex Bolt M10x50 Full Thread
8	813890	13-25	Hex Bolt M16x100
9	860166	26-50	Washer M16
10	917206	13-25	Nylock Nut M16
11	813690	13-25	Hex Bolt M12x90
12	T920261	26-50	Washer M12
13	852162	13-25	Nylock Nut M12
14	813520	52-100	Hex Bolt M10x20
15	190104	26-100	Hex Nut M10
16	190909	52-100	Washer Ø22, Ø10.5-4 mm
17	190125	26-50	Knife 3 mm
	190126	26-50	Knife 2 mm
18	813645	13-25	Hex Bolt M12x45

FIGUR 4

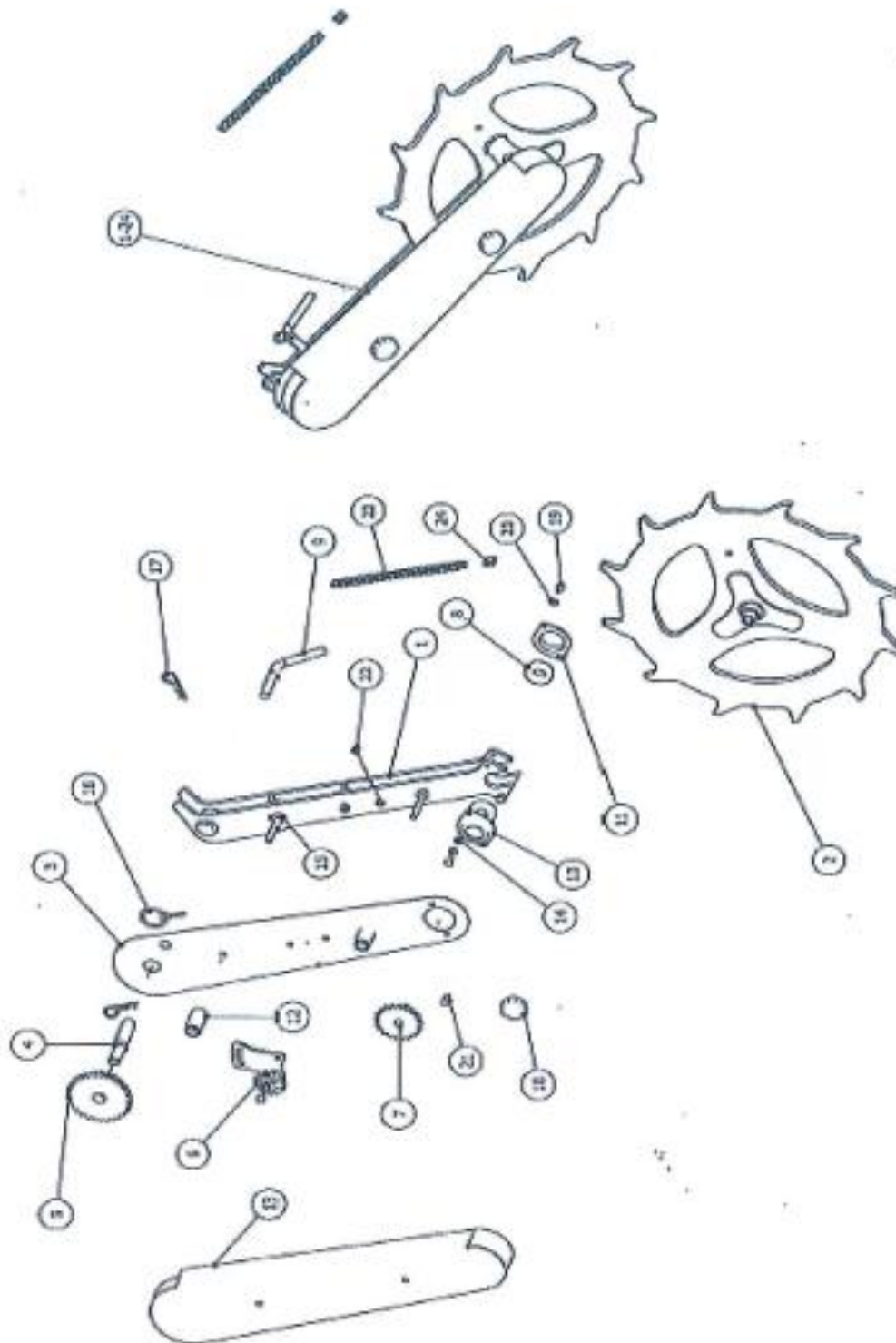

**SPARE PARTS FIG. 4**

<b>Ref.</b>	<b>Part No.</b>	<b>Qty</b>	<b>Item Description</b>
1-24	190863	1	Drive Wheel COMPLETE
1	190861-A	1	Drive Wheel Arm
2	190861	1	Drive Wheel
3	190481	1	Inner Arm
4	190470	1	Axle for Drive Wheel
5	190473	1	Double Gear
6	190811	1	Chain Tensioner COMPLETE
7	190472	1	Gear 21z Black
8	870725	2	Ball Bearing 6205
9	190057	1	Adjustment Pin
10	UH215101	1	Bearing Housing
11	UH215101-U	1	Bearing Housing without hole
12	190855	2	Spacer Sleeve
13	190483	1	Chain Shield
14	240165	2	Bushing
15	190909	2	Washer Ø22xØ10.5x4 mm
16	921701	1	Pin
17	T921711	2	Hairpin Cotter Ø4x75
18	855360	2	Star Knob M10
19	813412	2	Hex Bolt M8x12
20	860158	9	Washer 8 mm
21	813420	5	Hex Bolt M8x20
22	852158	2	Nylock Nut M8
23	190479	1	Chain for Drive Wheel
24	190907	1	Chain Lock COMPLETE

FIGURE 5

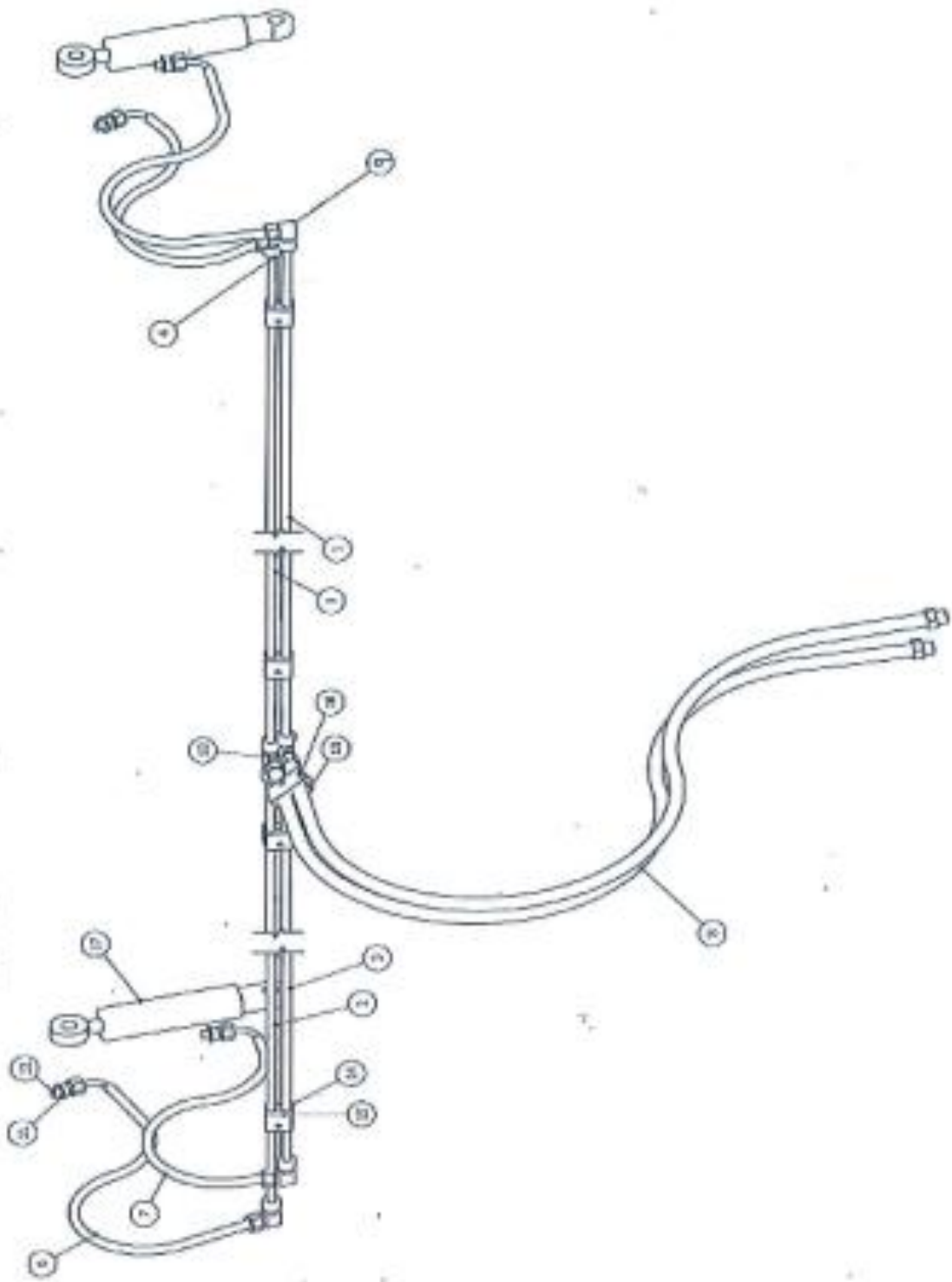

## SPARE PARTS FIG.5

Ref.	Part No.	Qty	Item Description
1-6	190931	1	Hydraulic Set COMPLETE 1.5 m
	190930	1	Hydraulic Set COMPLETE 2.0 m
	190928	1	Hydraulic Set COMPLETE 2.5 m
	1909229	1	Hydraulic Set COMPLETE 3.0 m
1	190910-1.5	2	Hydraulic Pipe 1.5 m
	190910-2.0	2	Hydraulic Pipe 2.0 m
	190910-2.5	2	Hydraulic Pipe 2.5 m
	190910-3.0	2	Hydraulic Pipe 3.0 m
2	190911-1.5	1	Hydraulic Pipe 1.5 m
	190911-2.0	1	Hydraulic Pipe 2.0 m
	190911-2.5	1	Hydraulic Pipe 2.5 m
	190911-3.0	1	Hydraulic Pipe 3.0 m
3	190912-1.5	1	Hydraulic Pipe 1.5 m
	190912-2.0	1	Hydraulic Pipe 2.0 m
	190912-2.5	1	Hydraulic Pipe 2.5 m
	190912-3.0	1	Hydraulic Pipe 3.0 m
4	190913	8	Nut 3/8"
6	190915	2	Hydraulic Hose 1/4", long
7	190916	2	Hydraulic Hose 1/4", short
8	190917	2	Hydraulic Hose 3/8" 1500 mm
9	190918	4	Hydraulic Elbow 3/8"
10	190919	2	Hydraulic Tee 3/8"
11	190920	4	Dowel Seal 1/4"
12	190921	4	Nozzle 1/4"
13	190922	2	Clamp 16 mm
14	190923	8	Clamp 12 mm
15	190926	4	Lock Plate 12 mm Clamp
16	190927	1	Lock Plate 16 mm Clamp
17	190878	2	Hydraulic Cylinder



## EU - DECLARATION OF CONFORMITY

### Responsible person

Name                      Atle Årsland  
Position                 General Manager  
Company                 Underhaug AS  
Address                 Torlandsvegen 3  
                               4365 Nærbø, NORWAY  
Phone                    +47 51 43 49 78

### Declares that the following machine:

Manufacturer:         Underhaug AS  
Type:                    UM 7926/7934/7942/7950/7966 - *Direct Seeding machines*

Serial Number:  
Production Year:

complies with the following directive:

Maximum regulation 554 (for 2009-05-20-554) and meets essential health and safety requirements.

Basic standard ISO 12100

A handwritten signature in blue ink, appearing to read "Atle Årsland", written over a horizontal line.

Atle Årsland

Nærbø, date



Torlandsvegen 3 – P.Box 183

N-4367 Nærbø, Norway

Phone: +47 51 43 49 78

Email: [post@underhaug.no](mailto:post@underhaug.no)

[www.underhaug.no/eng](http://www.underhaug.no/eng)